

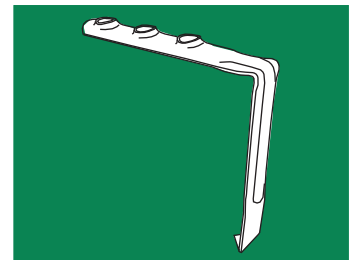

# QuickClamp *for Aluminum Forms*

Aluminum Form Hardware



**AFC-1** Foam Clamp

MADE IN USA

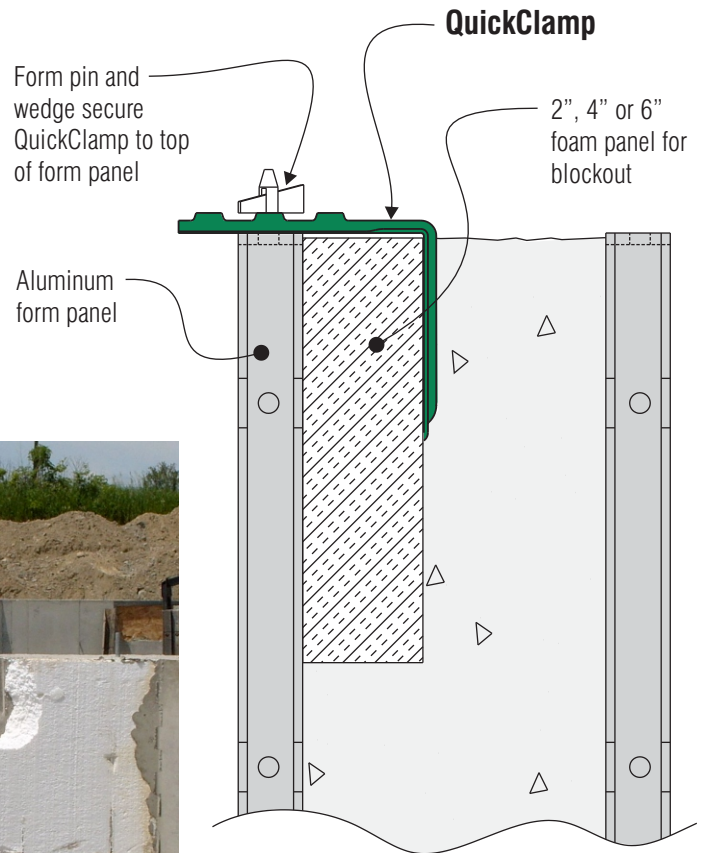
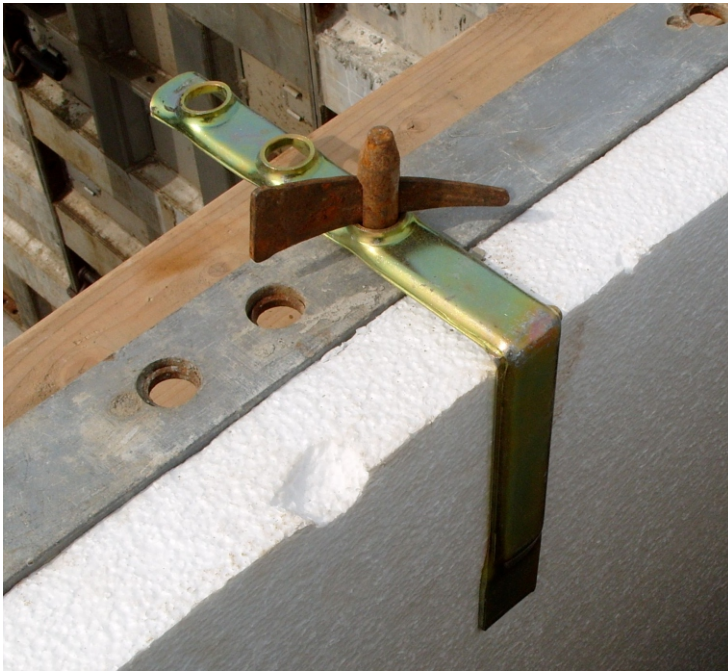

## Adjustable bracket for holding foam panels to aluminum form panels

Fast way to form brickledge and other blockouts

Steel Dog® **QuickClamps** make it easy to form brickledge and other blockouts on foundation walls when using aluminum form panels. The adjustable **QuickClamp** attaches to the top of the form panel with a standard form pin and wedge and holds consumable foam panels tight against the inside form face without fasteners.



### FEATURES:

- Three holes to accommodate 2", 4" or 6" foam
- Lightweight, but with formed rib for high strength
- Bent "claw" to firmly grip foam
- Designed to release easily from the concrete

**MATERIAL:** High strength steel

**FINISH:** Yellow zinc chromate

**APPLICATION:** Use a minimum of one QuickClamp per form panel. Additional QuickClamps may be needed for brickledge greater than 24" in depth. Do not use if part has become bent to greater than 90 degrees, as this may cause it to become locked in concrete.

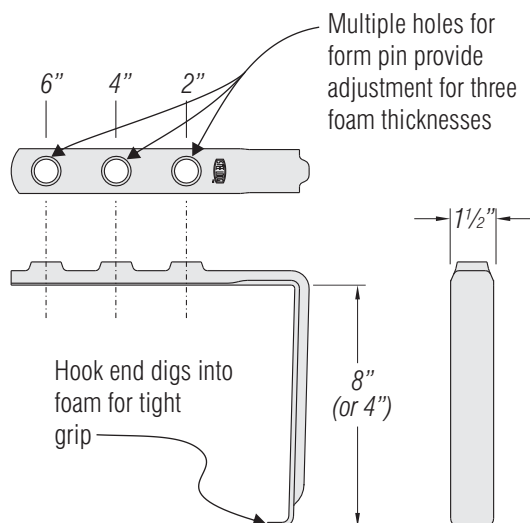

Product Code	<b>AFC-1</b>	<b>AFC-2</b>
Material	Steel	Steel
Finish	Zinc	Zinc
Foam thickness	2", 4" or 6"	2", 4" or 6"
Vert. Leg Length	8"	4"
Box Quantity	25 pcs	25 pcs
Box Weight	23 lbs	20 lbs

[steel-dog.com](http://steel-dog.com)