

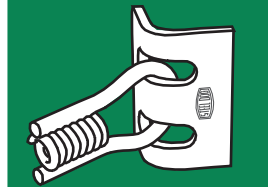

Coil Weld Angle Bracket™

One-Sided Forming Hardware



CWA-4 Coil-Stud™

MADE IN USA
Patent Pending

Inexpensive Weld Angle Bracket

Swivelling tie point for 1/2" coil rod

Steel Dog® **Coil Weld Angle Brackets™** are a low-cost way to tie formwork to steel structures where manual (stick, MIG) welding is to be used (*for stud welding, try the Steel Dog® Coil-Stud*). Typical application: one-sided forming against soldier piles or sheet piling.

FEATURES:

- Swivel loop coil tie end to accommodate misalignment between bracket placement and formwork tie location.
- Accepts standard 1/2" coil rod or 1/2"-13 NC rod (SCS-4NC)
- Eliminates expensive external bracing or welding.

MATERIAL: Bracket: HSLA Grade 50 steel. Swivel loop wire is AISI C1035.

FINISH: None.

MAXIMUM SAFE WORKING LOAD: 4500 Lbs. (2-to-1 safety factor)

when welded as directed below. When properly welded, this load may be applied to the coil loop at any permissible orientation ($\pm 30^\circ$ in "A" rotation, and $\pm 55^\circ$ in "B" rotation, or any combination of the two).

INSTALLATION:

- Coil Weld Angle Brackets **should be welded by a certified welder using industry standard AWS practices.**
- The use of low hydrogen welding wire or rod is recommended.
- Bracket should be welded with a continuous fillet where both 3" wide legs contact base metal. Fillets should extend around the ends of each leg (see diagrams below).

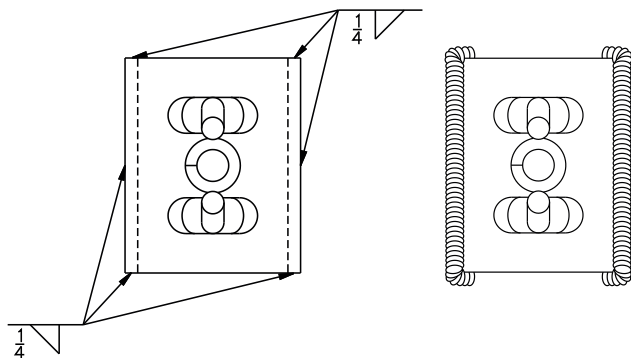
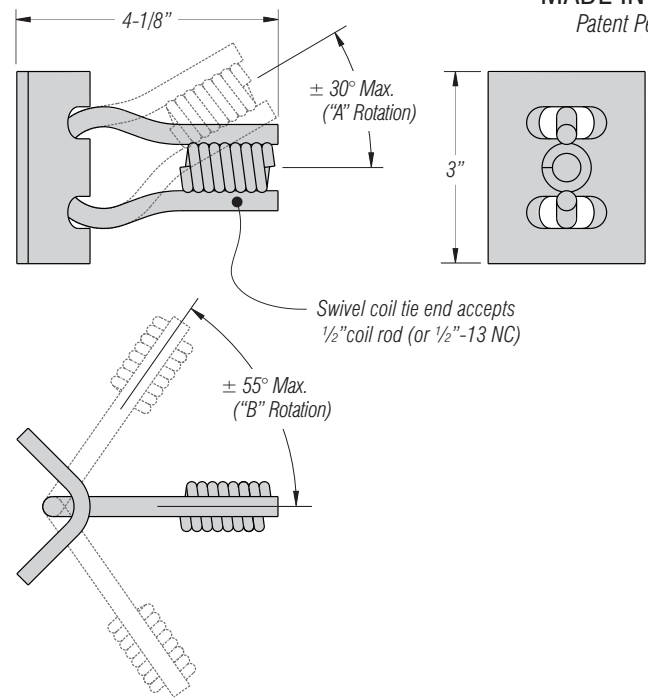

		CWA-4: Accepts 1/2" coil rod only.
		CWA-4NC: Coil is tapped to accept both 1/2" coil rod AND 1/2"-13 NC machine threads
Product Code	CWA-4	CWA-4NC
Safe Working Load*	4500 lbs	
Accepts Threaded Rod:	Yes	Yes
1/2" coil rod	No	Yes
1/2"-13 NC	3/16"	
Minimum Base Metal Thickness	50	
Box Quantity	40 lbs	
Box Weight		

*For Coil Weld Angle Bracket itself at approximately 2-to-1 Safety Factor. ACTUAL ALLOWABLE LOAD WILL DEPEND ON INSTALLATION AND STRENGTH OF WELD.