

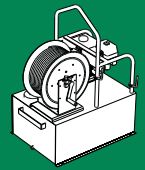

Form Release Oil Sprayer

Forming Hardware



S-1000 Form Oil Sprayer

Uncompromising Heavy Duty Form Oil Sprayer

In line with the Steel Dog way of manufacturing, our form oil sprayer combines reliability and convenience to give you a machine you can depend on.

FEATURES:

- Industry leading Honda GX 120 4 stroke engine
- Constant, 150 PSI of pressure regardless of engine RPM
- Adjustable flow control
- Optional self retracting hose
- Single or dual sprayer nozzle
- 3ft or 4ft chrome plated sprayer wand
- Quick connect fittings
- Cartridge style filter with sediment bowl

TANK MATERIAL: 12 Gauge steel

FINISH: 2 part, high performance polyurethane paint



RELIABILITY

Like all Steel Dog products this unit is made in America at our factory in Westport, Mass. We source the highest quality parts available and test each unit.

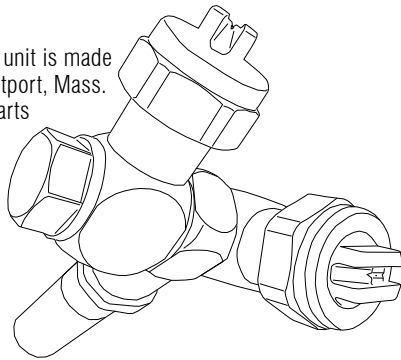

PERFORMANCE

The Steel Dog form oil sprayer outputs a consistent stream of release agent. The dual-jet nozzle head directs the flow in two directions simultaneously allowing you to cover both inside faces of the wall at once.

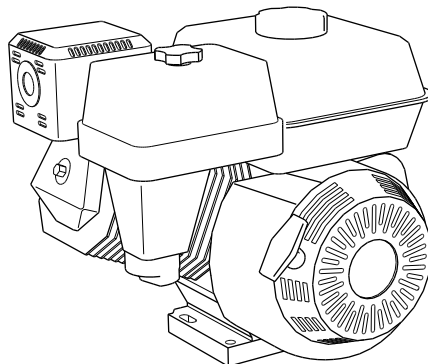
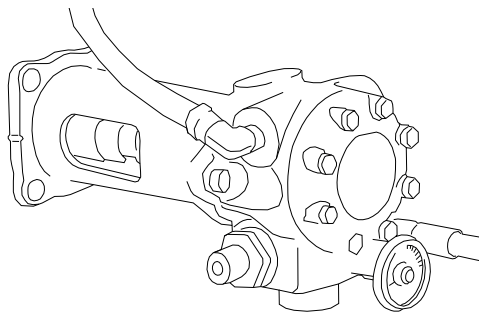

REEL

Most form oil sprayers fall short when it comes to hose management. Not the S-1000. Choose between a manual, hand-crank reel, or a spring loaded, Self-retracting reel.

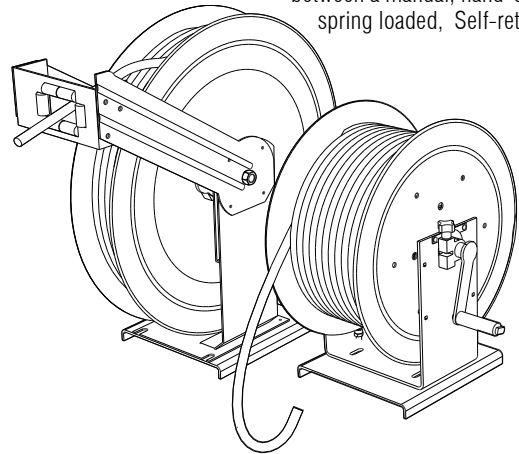

WARRANTY

All Steel Dog® S-1000 series sprayers come standard with a 1 year, replacement warranty. Limitations include, the Honda engine (which carries it's own separate warranty) and the sprayer hose.

S-1000 Series

The S-1000 comes in three different models: No reel, Manual Reel and Self-Retracting Reel. See below for specific specs

S-1000 NR No Reel

Steel Dog® form sprayer with 100ft of hose. Get the job done with standard configuration of the S-1000. Conveniently wrap the hose around the tank.

TANK FINISH: 2 part high performance polyurethane paint

TANK CAPACITY: 30 gallons

PUMP OUTPUT: factory set at 150psi (adjustable between 100psi and 200psi)

ENGINE: Honda GX 120 (4hp)

HOSE: 3/8" or 1/4"

Hose	3/8" or 1/4" 100ft
Total Weight (Dry)	157 lbs
Length (L)	32"
Width (W)	22 1/8"
Height (H)	27 3/4"

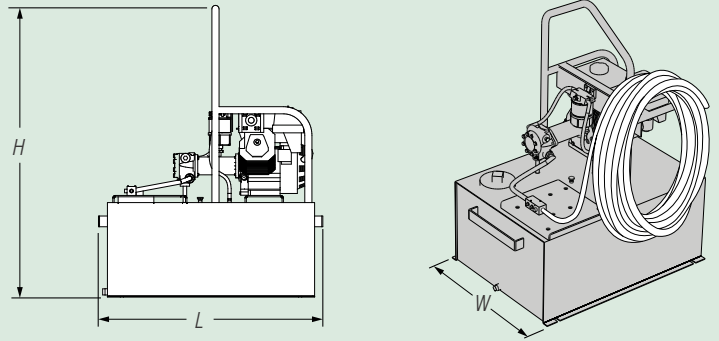

S-1000 CR Manual Reel

Steel Dog® form sprayer with 150ft of hose and manual hand crank reel. The addition of a hand crank reel makes operation quick and easy. Pull out as much hose as you need for the job. When finished simply pop the wand off and wind the hose back in with the hand crank.

TANK FINISH: 2 part high performance polyurethane paint

TANK CAPACITY: 30 gallons

PUMP OUTPUT: factory set at 150psi (adjustable between 100psi and 200psi)

ENGINE: Honda GX 120 (4hp)

HOSE: 3/8" or 1/4"

Hose	3/8" OR 1/4" 150ft
Total Weight (Dry)	200 lbs
Length (L)	32 5/8"
Width (W)	25 1/8"
Height (H)	32 1/4"

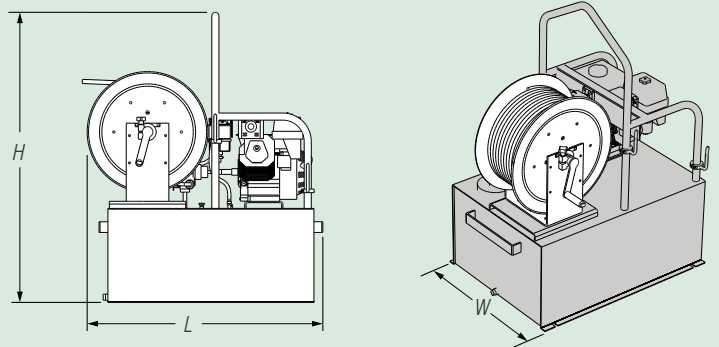

S-1000 SR Auto Retracting Reel

Steel Dog form sprayer with 100ft of hose and a spring loaded self retracting reel. A self retracting reel is the ultimate compliment to a form sprayer. Not only is it simple to deploy, but cleanup is effortless. Give the hose a firm tug and the heavy duty reel neatly winds the hose for you.

TANK FINISH: 2 part high performance polyurethane paint

TANK CAPACITY: 30 gallons

PUMP OUTPUT: factory set at 150psi (adjustable between 100psi and 200psi)

ENGINE: Honda GX 120 (4hp)

HOSE: 3/8" or 1/4"

Hose	3/8" 100ft
Total Weight (Dry)	228 lbs
Length (L)	37 1/2"
Width (W)	22 1/8"
Height (H)	39 1/8"

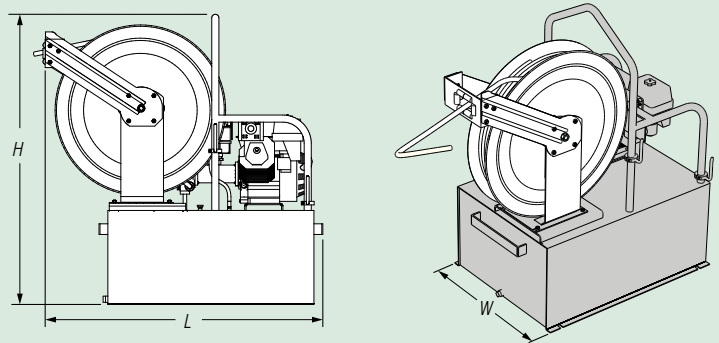

Components

Wand Options

Single Nozzle with Pre-bent Wand

Pre-bent wand with single jet and fixed stream direction.

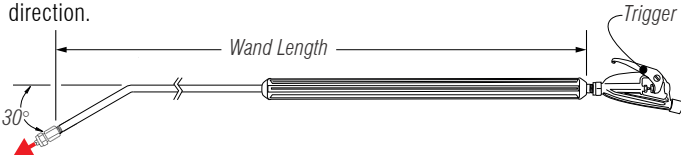

Dual Nozzle with Straight Wand

Simultaneously sprays both inside faces of form work. Dual jet nozzle with adjustable stream direction.

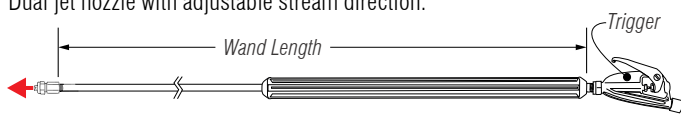

Honda Engine

The S-1000 form oil sprayer is designed to maximize productivity and eliminate down time. Powered by an industry leading Honda GX 120 engine.

Engine Specs

Engine Type	Air Cooled 4-Stroke OHV
Net Power Output	4 HP (2.6 kW) @3,600 RPM
Compression Ratio	8.5:1
Starting System	Recoil
Lubrication System	Splash
Oil Capacity	0.59 US quart (0.56L)
Fuel Tank Capacity	2.1 US quarts (2.0L)
Fuel	Unleaded 86 octane or higher
Dry Weight	29 lbs (13.0 kg)

