

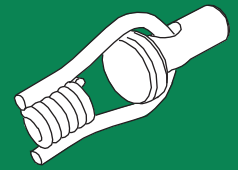

# Coil-Stud™

One-Sided Forming Hardware



SCS-4 Coil-Stud™

MADE IN USA  
Patent Pending

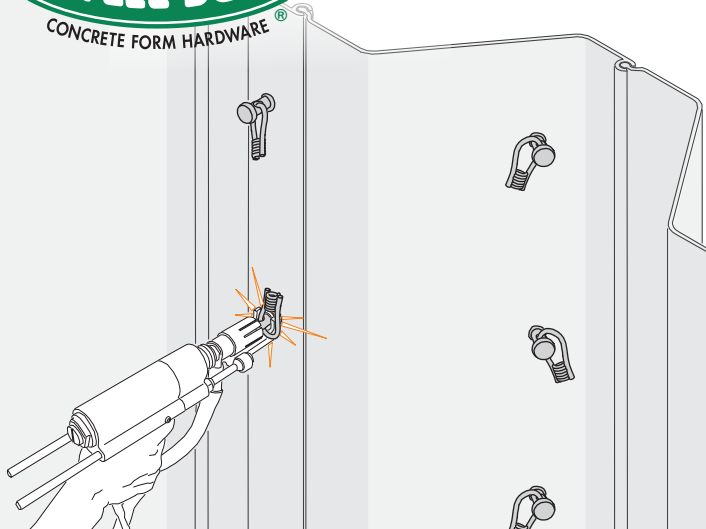

## Fast, Low-Cost Method of Attaching Formwork to Steel Structures

Steel Dog® Coil-Studs™ provide low-cost attachment points for coil hardware-based form ties onto steel structures. Typical application: one-sided forming against soldier piles or sheet piling.

### FEATURES:

- Standard 3/4" arc weld stud.
- Swivel loop coil tie end to accommodate misalignment between stud placement and formwork tie location.
- Accepts standard 1/2" coil rod or 1/2"-13 NC rod (SCS-4NC)
- **Welds in seconds** with standard stud welding equipment.
- Eliminates expensive external bracing or welding.

**MATERIAL:** Stud is ASTM A108, C1010-1020. Swivel loop wire is AISI C1035.

**FINISH:** None.

**MAXIMUM SAFE WORKING LOAD: 4500 Lbs.** (2-to-1 safety factor).

*Actual Safe Working Load will depend on quality of weld to substrate.*

### INSTALLATION:

- Coil-Studs™ may be welded with standard stud welding equipment designed for **drawn arc stud welding**, in which an arc is struck between stud and base metal and the stud plunged into the molten steel produced by the arc, creating the weld. The molten steel is contained by a disposable ceramic ferrule (included). A proper weld will be as strong as the stud itself.
- Alternatively, the stud can be flipped around and the head of the stud welded conventionally to the base metal, by either stick or MIG welding equipment.
- Connection to formwork is made with 1/2" coil rod directly, or with coil rod and Transition Ties™ (see opposite side).

### STUD WELDING:

- **Welder** A stud welder capable of at least 1500 amps output is necessary.
- **Gun** The Coil-Stud™ is compatible with most arc stud welders capable of welding 3/4" shear connector studs. The Coil-Stud™ is shorter than most shear connector studs, however, so an open-style ferrule foot, thin enough not to interfere with the coil loop must be used (see gun drawing). Ensure that coil loop does not contact ferrule foot at end of plunge stroke.
- **Ferrule** The supplied ceramic ferrule is designed for welding to flat, vertical surfaces. Ferrules available for horizontal surfaces or for corners.
- **Procedure** See opposite side

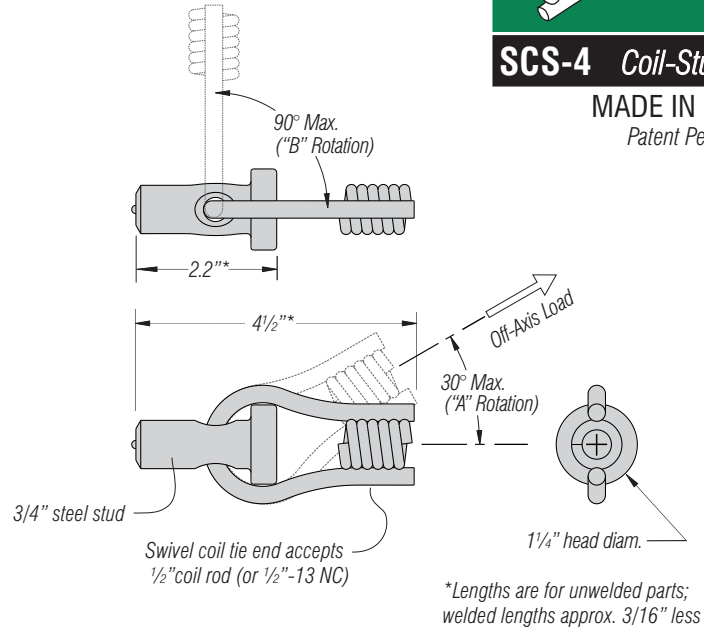

	SCS-4	SCS-4NC	SCS-D15
Product Code	SCS-4	SCS-4NC	SCS-D15
Safe Working Load*	4500 lbs	4500 lbs	4500 lbs
Stud Size	3/4"	3/4"	3/4"
Ceramic Ferrule for Vertical Surfaces	Included	Included	Included
Threaded Rod:	1/2" coil rod	1/2" coil rod	15mm rod
		1/2"-13 NC	
Minimum Base Metal Thickness	3/16"	3/16"	3/16"
Box Quantity	50	50	50
Box Weight	32 lbs	32 lbs	43 lbs

\*For Coil-Stud itself at approximately 2-to-1 Safety Factor. ACTUAL ALLOWABLE LOAD WILL DEPEND ON INSTALLATION AND STRENGTH OF WELD.

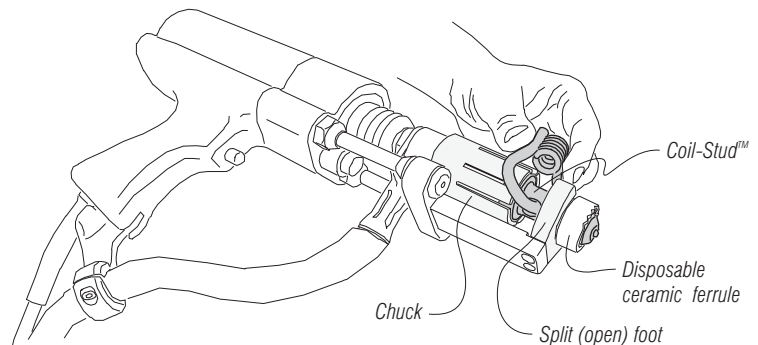

Steel Dog® Coil-Studs™ can be welded with the same setup used for 3/4" shear connectors. Switching between the two is simply a matter of adjusting the length between the ferrule foot and the chuck.

## ATTACHING STEEL PLY® PANELS TO SHEET PILING

Coil-Studs™ and Loop-Coil™ Ties allow you to connect to sheet piling in a number of ways:

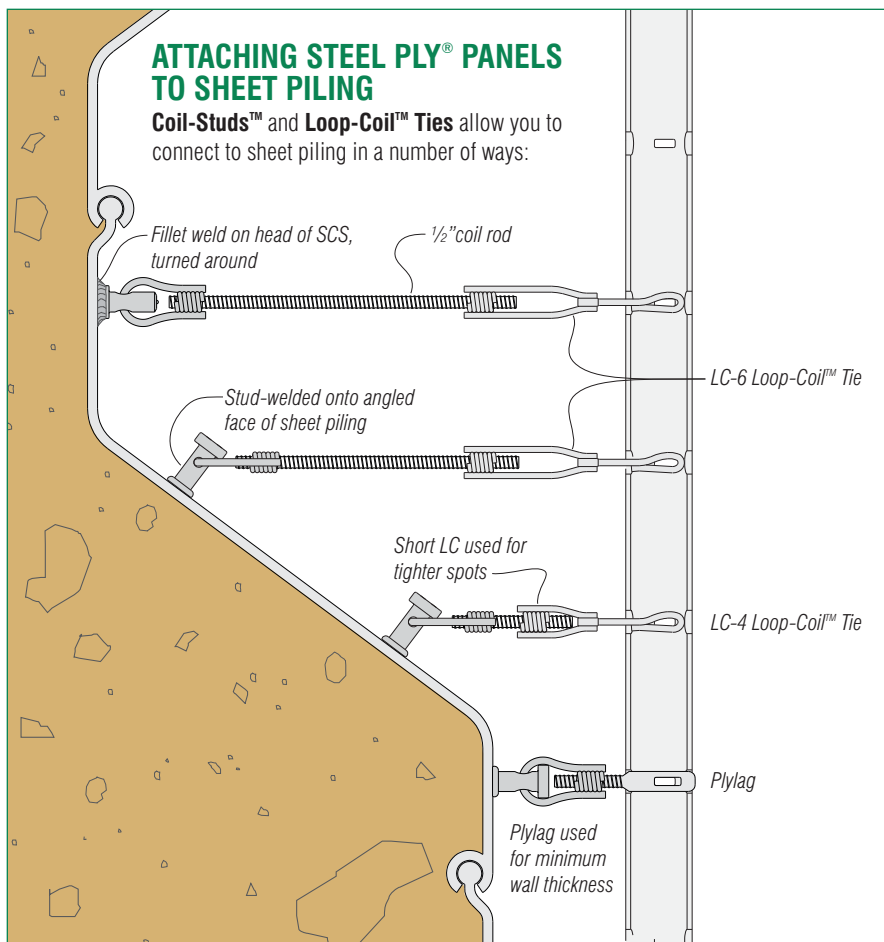

## CAUTION

- DO NOT EXCEED THE SAFE WORKING LOAD (4500lbs.)
- COIL-STUDS ARE INTENDED ONLY FOR THE TEMPORARY ATTACHMENT OF FORMWORK TO MILD STEEL STRUCTURES FOR THE PLACEMENT OF CONCRETE. NOT FOR USE AS A PERMANENT LOAD CARRYING ELEMENT
- WELDING SHOULD BE PERFORMED ONLY BY EXPERIENCED PERSONNEL, TRAINED IN THE EQUIPMENT BEING USED
- BE SURE THAT THE THREADED ELEMENT EXTENDS AT LEAST 1/4" BEYOND COIL
- ADJUST EACH TIE TO PROPER LENGTH TO ENSURE EVEN DISTRIBUTION OF LOAD
- DO NOT USE ANY PARTS THAT APPEAR TO BE DAMAGED, CRACKED, OR ABUSED

## ONE-SIDED FORMING:

- COIL-STUDS ARE RATED TO CARRY A SPECIFIC LOAD; THE FIELD WELDS YOU MAKE MUST CARRY NO LESS. MAKE SURE YOU UNDERSTAND THE FORCES INVOLVED. IT IS THE RESPONSIBILITY OF THE USER TO ENSURE ADEQUATE ANCHORAGE TO EXISTING WALL
- ALWAYS CALCULATE TIE LOADS BASED ON POUR RATE, TEMPERATURE, TIE SPACING, ETC., AND DO NOT EXCEED MAXIMUM POUR RATE NEEDED TO KEEP TIE LOADS BELOW SAFE WORKING LOAD

## STUD WELDING PROCEDURE

### PREPARATION:

- Base metal surface must be clean and dry. Remove rust, paint, oil, etc.
- Ferrules must be dry
- Do not weld if base metal temperature is below 0° F
- Ensure good ground connection to base metal

### WELDING:

- Consult welding equipment manufacturer's literature for recommended weld settings for 3/4" steel studs welded to steel
- Adjust stud gun to accommodate Coil-Stud so that swivel coil loop does not impede free and full movement of stud during welding
- Studs must be welded perpendicular to surface only

**INSPECTION:** There should be a full 360° weld fillet around stud. Reject any studs with a partial weld or undercut.

**TESTING:** After setting up welder, test at least two Coil-Studs™ before further welding. Bend at least 30 degrees from initial position with hammer or bending tool. Repeat bend test every 1/2 hour, or after any change in weld settings, operator, or any other welding conditions.

## Off-the-Shelf Solutions for Many Forming Problems

### For Most Forming Systems

The Steel Dog® Coil-Stud™ is part of a versatile family of off-the-shelf, interchangeable forming components using industry-standard 1/2" coil rod as the threaded element. Choose the components for your form system and application and get an adjustable, labor-saving, no lead-time forming solution.

